

1949

> VEGA <

MOTOROVÝ MODEL

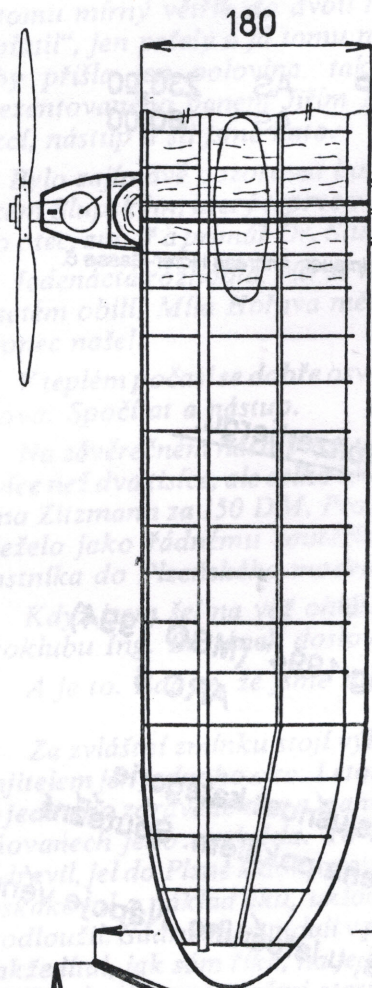

ROZPĚTÍ	1200 mm
DÉLKA	870 mm
PLOCHA KŘ.	18,9 dm
PLOCHA VÝŠ.	4,4 dm
PLOCHA CEL.	23,3 dm
PROFIL KŘ.	G 5 P
PROFIL VÝŠ.	SNÍŽENÝ CLARK-Y
VÁHA	380 g
ZATÍŽENÍ	16 g
MOTOR	AMA 2,5 ccm

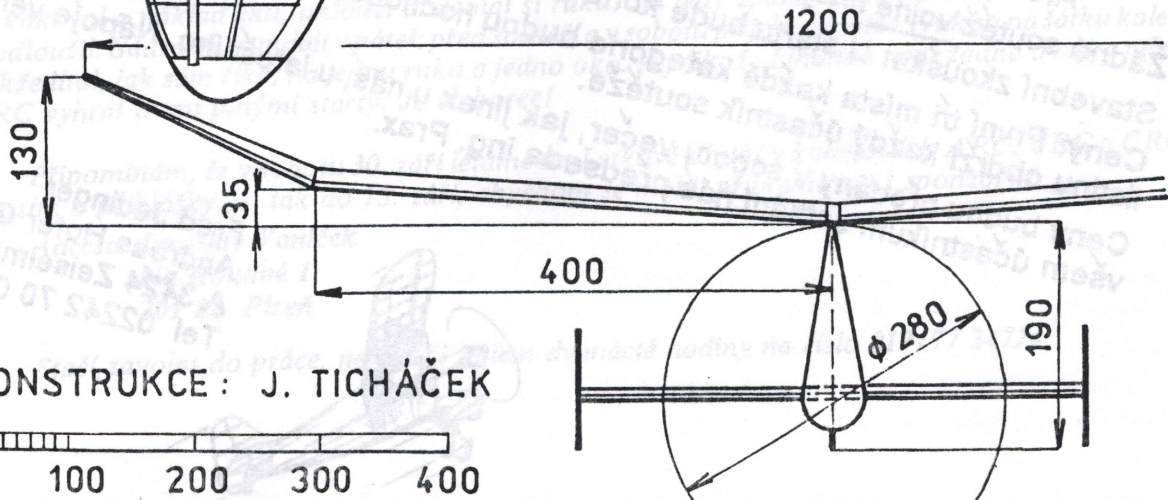
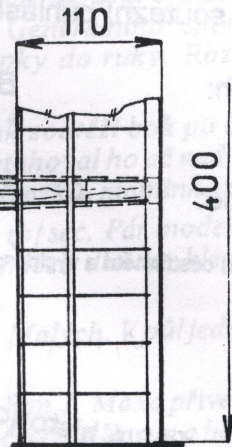

KONSTRUKCE : J. TICHÁČEK

